

# Simple Class A Amplifier

## A 10-W design giving subjectively better results than class B transistor amplifiers

by J. L. Linsley Hood, M.I.E.E.

During the past few years a number of excellent designs have been published for domestic audio amplifiers. However, some of these designs are now rendered obsolescent by changes in the availability of components, and others are intended to provide levels of power output which are in excess of the requirements of a normal living room. Also, most designs have tended to be rather complex.

In the circumstances it seemed worth while to consider just how simple a design could be made which would give adequate output power together with a standard of performance which was beyond reproach, and this study has resulted in the present design.

### Output power and distortion

In view of the enormous popularity of the Mullard "5-10" valve amplifier, it appeared that a 10-watt output would be adequate for normal use; indeed when two such amplifiers are used as a stereo pair, the total sound output at full power can be quite astonishing using reasonably sensitive speakers.

The original harmonic distortion standards for audio amplifiers were laid down by D. T. N. Williamson in a series of articles published in *Wireless World* in 1947 and 1949; and the standard, proposed by him, for less than 0.1% total harmonic distortion at full rated power output, has been generally accepted as the target figure for high-quality audio power amplifiers. Since the main problem in the design of valve audio amplifiers lies in the difficulty in obtaining adequate performance from the output transformer, and since modern transistor circuit techniques allow the design of power amplifiers without output transformers, it seemed feasible to aim at a somewhat higher standard, 0.05% total harmonic distortion at full output power over the range 30Hz-20kHz. This also implies that the output power will be constant over this frequency range.

### Circuit design

The first amplifier circuit of which the author is aware, in which a transformerless transistor design was used to give a standard of performance approaching that of the "Williamson" amplifier, was that published in *Wireless World* in 1961 by Tobey and Dinsdale. This employed a class B output stage, with series connected transistors in quasi-complementary symmetry. Subsequent high-quality transistor power amplifiers have largely tended to follow the design principles outlined in this article.

The major advantage of amplifiers of this type is that the normal static power dissipation is very low, and the overall power-conversion efficiency is high. Unfortunately there are also some inherent disadvantages due to the intrinsic dissimilarity in the response of the two halves of the push-pull pair (if complementary transistors are used in unsymmetrical circuit arrangement) together with some cross-over distortion due to the  $I_c/V_b$  characteristics. Much has been done, particularly by Bailey<sup>1</sup>, to minimise the latter.

An additional characteristic of the class B output stage is that the current demand of the output transistors increases with the output signal, and this may reduce the output voltage and worsen the smoothing of the power supply, unless this is well designed. Also, because of the increase in current with output power, it is possible for a transient overload to drive the output transistors into a condition of thermal runaway, particularly with reactive loads, unless suitable protective circuitry is employed. These requirements have combined to increase the complexity of the circuit arrangement, and a well designed low-distortion class B power amplifier is no longer a simple or inexpensive thing to construct.

An alternative approach to the design of a transistor power amplifier combining good performance with simple construction is to use the output transistors in a class A configuration. This avoids the problems of asymmetry in quasi-complementary circuitry, thermal runaway on transient overload, cross-over distortion and signal-dependent variations in power supply current demand. It is, however, less efficient than a class B circuit, and the output transistors must be mounted on large heat sinks.

The basic class A construction consists of a single transistor with a suitable collector load. The use of a resistor, as in Fig. 1(a), would be a practical solution, but the best power-conversion efficiency would be about 12%. An l.f. choke, as shown in Fig. 1(b), would give much better efficiency, but a properly designed component would be bulky and expensive, and remove many of the advantages of a transformerless design. The use of a second, similar, transistor as a collector load, as shown in Fig. 1(c), would be more convenient in terms of size and cost, and would allow the load to be driven effectively in push-pull if the inputs of the two transistors were of suitable magnitude and opposite in phase. This requirement can be achieved if the driver transistor is connected as shown in Fig. 2.

This method of connection also meets one of the most important requirements of a low distortion amplifier - that the basic linearity of the amplifier should be good, even in the absence of feedback. Several factors contribute to this. There is the tendency of the  $I_c/V_b$  non-linearity of the characteristics of the output transistors to cancel, because during the part of the cycle in which one transistor is approaching cut-off the other is turned full on. There is a measure of internal feedback around the loop Tr1, Tr2, Tr3 because of the effect which the base impedance characteristics of Tr1 have on the output current of Tr3. Also, the driver transistor Tr3, which has to deliver a large voltage swing, is operated under conditions which favour low harmonic distortion - low output load impedance, high input impedance. A practical power amplifier circuit using this type of output stage is shown in Fig. 3.

The open loop gain of the circuit is approximately 600 with typical transistors. The closed loop gain is determined, at frequencies high enough for the impedance of C3 to be small in comparison to R4, by the ratio  $(R3 + R4)/R4$ . With the values indicated in Fig. 3, this is 13. This gives a feedback factor of some 34dB, and an output impedance of about 160 milliohms.

Since the circuit has unity gain at d.c., because of the inclusion of C3 in the feedback loop, the output voltage,  $V_e$ , is held at the same potential as the base of Tr4 plus the base emitter potential of Tr4 and the small potential drop along R3 due to the emitter current of this transistor. Since the output transistor Tr1 will turn on as much current as is necessary to pull  $V_e$  down to this value, the resistor R2, which together with R1 controls the collector current of Tr2, can be used to set the static current of the amplifier output stages. It will also be apparent that  $V_e$  can be set to any desired value by small adjustments to R5 or R6. The optimum performance will be obtained when this is equal to half the supply voltage. (Half a volt or so either way will make only a small difference to the maximum output power obtainable, and to the other characteristics of the amplifier, so there is no need for great precision in setting this.)

Silicon planar transistors are used throughout, and this gives good thermal stability and a low noise level. Also, since there is no requirement for complementary symmetry, all the power stages can use n-p-n transistors which offer, in silicon, the best performance and lowest cost. The overall performance at an output level of 10 watts, or at any lower level, more than meets the standards laid down by Williamson. The power output and gain/frequency graphs are shown in Figs. 4 - 6, and the relationship between output power and total harmonic distortion is shown in Fig. 7. Since the amplifier is a straight-forward class A circuit, the distortion decreases linearly with output voltage. (This would not necessarily be the case in a class B system if any significant amount of cross-over distortion was present.) The analysis of distortion components at levels of the order of 0.05% is difficult, but it appears that the residual distortion below the level at which clipping begins is predominantly second harmonic.

### Stability, power output and load impedance

Silicon planar n-p-n transistors have, in general, excellent high frequency characteristics, and these contribute to the very good stability of the amplifier with reactive loads. The author has not yet found a combination of L and C which makes the system unstable, although the system will readily become oscillatory with an inductive load if R3 is shunted by a small condenser to cause roll-off at high frequencies.

The circuit shown in Fig. 3 may be used, with very little modification to the component values, to drive load impedances in the range 3 - 15 ohms. However, the chosen output power is represented by a different current/voltage relationship in each case, and the current through the output transistors and the output-voltage swing will therefore also be different. The peak-voltage swing and mean output current can be calculated quite simply from the well-known relationships  $W=I^2.R$  and  $V=I.R$ , where the symbols have their customary significance. (It should be remembered, however, that the calculation of output power is based on r.m.s. values of current and voltage, and that these must be multiplied by 1.414 to obtain the peak values, and that the voltage swing measured is the peak-to-peak voltage, which is twice the peak value.)

When these calculations have been made, the peak-to-peak voltage swing for 10 watts power into a 15-Ohm load is found to be 34.8 volts. Since the two output transistors bottom at about 0.6 volts each, the power supply must provide a minimum of 36 volts in order to allow this output. For loads of 8 and 3 ohms, the minimum h.t. line voltage must be 27V and 17 volts respectively. The necessary minimum currents are 0.9, 1.2 and 2.0 amps. Suggested component values for operation with these load impedances are shown in Table 1. C3 and C1 together influence the voltage and power roll-off at low audio frequencies. These can be increased in value if a better low-frequency performance is desired than that shown in Figs. 4 - 6.

Since the supply voltages and output currents involved lead to dissipations in the order of 17 watts in each output transistor, and since it is undesirable (for component longevity) to permit high operating temperatures, adequate heat sink area must be provided for each transistor. A pair of separately mounted 5in by 4in finned heatsinks is suggested. This is, unfortunately, the penalty which must be paid for class A operation. For supplies above 30V Tr1 and Tr2 should be MJ481s and Tr3 a 2N1613.

If the output impedance of the pre-amplifier is more than a few thousand ohms, the input stage of the amplifier should be modified to include a simple f.e.t. source follower circuit, as shown in Fig. 8. This increases the harmonic distortion to about 0.12%, and is therefore (theoretically) a less attractive solution than a better pre-amplifier. A high frequency roll-off can then be obtained, if necessary, by connecting a small capacitor between the gate of the f.e.t. and the negative (earthy) line.

ZL	V	I	R1	R2	C1	C2	V <sub>IN (rms)</sub>
3Ω	17V	2.0A	47Ω	180Ω	500μF 25V	5000μF 25V	0.41V
8Ω	27V	1.2A	100Ω	560Ω	250μF 40V	2500μF 50V	0.66V
15Ω	36V	0.9A	150Ω	1.2kΩ	250μF 40V	2500μF 50V	0.90V

**Table 1. Summary of component combinations for different load impedances.**

### Suitable transistors

Some experiments were made to determine the extent to which the circuit performance was influenced by the type and current gain of the transistors used. As expected the best performance was obtained when high-gain transistors were used, and when the output stage used a matched pair. No adequate substitute is known for the 2N697 / 2N1613 type used in the driver stage, but examples of this transistor type from three different manufacturers were used with apparently identical results. Similarly, the use of alternative types of input transistor produced no apparent performance change, and the Texas Instruments 2N4058 is fully interchangeable with the Motorola 2N3906 used in the prototype.

The most noteworthy performance changes were found in the current gain characteristics of the output transistor pair, and for the lowest possible distortion with any pair, the voltage at the point from which the loudspeaker is fed should be adjusted so that it is within 0.25 volt of half the supply line potential. The other results are summarized in Table 2.

The transistors used in these experiments were Motorola MJ480 / 481, with the exception of (6), in which Texas 2S034 devices were tried. The main conclusion which can be drawn from this is that the type of transistor used may not be very important, but that if there are differences in the current gains of the output transistors, it is necessary that the device with the higher gain shall be used in the position of Tr1.

When distortion components were found prior to the onset of waveform clipping, these were almost wholly due to the presence of second harmonics.

Test No.	Current Gain Tr1	Current Gain Tr2	Distortion (at 9 watts)
1	135	135	0.06%
2	40	120	0.4%
3	120	40	0.12% (pair 2 reversed)
4	120	100	0.09%
5	100	120	0.18% (pair 5 reversed)
6	50	40	0.1%

**Table 2. Relation of distortion to gain-matching in the output stage.**

### Constructional notes

**Amplifier.** The components necessary for a 10 + 10 watt stereo amplifier pair can be conveniently be assembled on a standard "Lektrokit" 4in x 4.75in s.r.b.p. pin board, as shown in the photographs, with the four power transistors mounted on external heat sinks. Except where noted the values of components do not appear to be particularly critical, and 10% tolerance resistors can certainly be used without ill effect. The lowest noise levels will however be obtained with good quality components, and with carbon-film, or metal-oxide, resistors.

**Power Supply.** A suggested form of power supply unit is shown in Fig. 9(a). Since the current demand of the amplifier is substantially constant, a series transistor smoothing circuit can be used in which the power supply output voltage may be adjusted by choice of the base current input provided by the emitter follower Tr2 and the potentiometer VR1. With the values of the reservoir capacitor shown in Table 3, the ripple level will be less than 10mV at the rated output current, provided that the current gain of the series transistors is greater than 40. For output currents up to 2.5 amps, the series transistors indicated will be adequate, provided that they are mounted on heat sinks appropriate to their loading.

However, at the current levels necessary for operation of the 3-ohm version of the amplifier as a stereo pair, a single MJ480 will no longer be adequate, and either a more suitable series transistor must be used, such as the Mullard BDY20, with for example a 2N1711 as Tr2, or with a parallel connected arrangement as shown in Fig. 9(b).

Amp Z <sub>L</sub>	I <sub>OUT</sub>	V <sub>OUT</sub>	C1	Tr1/2	MR1	T1
15Ω	1A	37V	1000μF 50V	MJ480 / 2N697	5BO5	40V 1A
2 x 15Ω	2A	37V	5000μF 50V	MJ480 / 2N697	5BO5	40V 2A
8Ω	1.25A	27V	2000μF 40V	MJ480 / 2N697	5BO5	30V 1.25A
2 x 8Ω	2.5A	27V	5000μF 40V	MJ480 / 2N697	5BO5	30V 2.5A
3Ω	1.9A	18V	5000μF 30V	MJ480 / 2N697	5BO5	20V 2A
2 x 3Ω	3.8A	18V	10,000μF 30V	MJ480 / 2x2N697	7BO5T	20V 4A

**Table 3. Power-supply components**

The total resistance in the rectifier "primary" circuit, including the transformer secondary winding, must not be less than 0.25Ω. When the power supply, with or without an amplifier, is to be used with an r.f. amplifier-tuner unit, it may be necessary to add a 0.25μF (160V.w.) capacitor across the secondary winding of T1 to prevent transient radiation. The rectifier diodes specified are International Rectifier potted bridge types.

## Transistor protection circuit

The current which flows in the output transistor chain (Tr1, Tr2) is determined by the potential across Tr2, the values of R1 and R2, and the current gain and collector-base leakage current of Tr2. Since both these transistor characteristics are temperature dependant the output series current will increase somewhat with the temperature of Tr2. If the amplifier is to be operated under conditions of high ambient temperature, or if for some reason it is not practicable to provide an adequate area of heat-sink for the output transistors, it will be desirable to provide some alternative means for the control of the output transistor circuit current. This can be done by means of the circuit shown in Fig. 10. In this, some proportion of the d.c. bias current to Tr1 is shunted to the negative line through Tr7, when the total current flowing causes the potential applied to the base of Tr6 to exceed the turn-on value (about 0.5 volt). This allows very precise control of the series current without affecting the output power or distortion characteristics. The simpler arrangement whereby the current control potential for Tr7 is obtained from a series resistor in the emitter circuit of Tr1 leads, unfortunately, to a worsening of the distortion characteristics to about 0.15% at 8 watts, rising to about 0.3% at the onset of overload.

## Performance under listening conditions

It would be convenient if the performance of an audio amplifier (or loudspeaker or any other similar piece of audio equipment) could be completely specified by frequency response and harmonic distortion characteristics. Unfortunately, it is not possible to simulate under laboratory conditions the complex loads or intricate waveform structures presented to the amplifier when a loudspeaker system is employed to reproduce the everyday sounds of speech and music; so that although the square wave and low-distortion sine wave oscillators, the oscilloscope, and the harmonic distortion analyser are valuable tools in the design of audio circuits, the ultimate test of the final design must be the critical judgement of the listener under the most carefully chosen conditions his facilities and environment allow.

The possession of a good standard of reference is a great help in comparative trials of this nature, and the author has been fortunate in the possession, for many years, of a carefully and expensively built "Williamson" amplifier, the performance of which has proved, in listening trials, to equal or exceed, by greater or lesser margins, that of any other audio amplifier with which the author has been able to make comparisons.

However, in the past, when these tests were made for personal curiosity, and some few minutes could elapse in the transfer of input and output leads from one amplifier to the other, the comparative performance of some designs has been so close that the conclusion drawn was that there was really very little to choose between them. Some of the recent transistor power amplifier circuits gave a performance which seemed fully equal to that of the "Williamson", at least so far as one could remember during the interval between one trial and the next. It was, however, appreciated that this did not really offer the best conditions for a proper appraisal of the more subtle differences in the performance of already good designs, so a changeover switch was arranged to transfer inputs and outputs between any chosen pair of amplifiers, and a total of six amplifier units was assembled, including the "Williamson", and another popular valve unit, three class B transistor designs, including one of commercial origin, and the class A circuit described above. The frequency response, and total harmonic distortion characteristics, of the four transistor amplifiers was tested in the laboratory prior to this trial, and all were found to have a flat frequency response through the usable audio spectrum, coupled with low harmonic distortion content (the worst-case figure was 0.15%).

In view of these prior tests, it was not expected that there would be any significant difference in the audible performance of any of the transistor designs, or between them and the valve amplifiers. It was therefore surprising to discover, in the event, that there were discernable differences between the valve and the three class B transistor units. In fact, the two valve designs and the class A transistor circuit, and the three class B designs formed two tonally distinct groups, with closely similar characteristics within each group.

The "Williamson" and the present class A design were both better than the other valve amplifier, and so close in performance that it was almost impossible to tell which of the two was in use without looking at the switch position. In the upper reaches of the treble spectrum the transistor amplifier has perhaps a slight advantage.

The performance differences between the class A and the class B groups were, however, much more prominent. Not only did the class A systems have a complete freedom from the slight "edginess" found on some high string notes with all the class B units, but they appeared also to give a fuller, "rounder", quality, the attractiveness of which to the author much outweighs the incidental inconvenience of the need for more substantial power supply equipment and more massive heat sinks.

Some thought, in discussions with interested friends, has been given to the implications of this unlooked-for discovery, and a tentative theory has been evolved which is offered for what it is worth. It is postulated that these tonal differences arise because the normal moving-coil loudspeaker, in its associated housing, can present a very complex reactive load at frequencies associated with structural resonances, and that this might provoke transient overshoot when used with a class B amplifier, when a point of inflection in the applied waveform chanced to coincide with the point of transistor crossover, at which point, because of the abrupt change in the input parameters of the output transistors the loop stability margins and output damping will be less good. In these circumstances, the desired function of the power-amplifier output circuit in damping out the cone-response irregularities of the speaker may be performed worse at the very places in the loudspeaker frequency-response curve where the damping is most needed.

It should be emphasized that the differences observed in these experiments are small, and unlikely to be noticed except in direct side-by-side comparison. The perfectionist may, however, prefer class A to class B in transistor circuitry if he can get adequate power for his needs that way.

### Listener fatigue

In the experience of the author, the performance of most well-designed audio power amplifiers is really very good, and the differences between one design and another are likely to be small in comparison with the differences between alternative loudspeaker systems, for example, and of the transistor designs so far encountered, not one could be considered as unpleasing to the ear. However, with the growing use of solid-state power amplifiers, puzzling tales of "listener fatigue" have been heard among the *cognoscenti*, as something which all but the most expensive transistor amplifiers will cause the listener, in contradistinction with good valve-operated amplifiers. This seemed to be worth investigation, to discover whether there was any foundation for this allegation.

In practice it was found that an amplifier with an impeccable performance on paper could be quite worrying to listen to under certain conditions. This appears to arise and be particularly associated with transistor power amplifiers because most of these are easily able to deliver large amounts of power at supersonic frequencies, which the speakers in a high quality system will endeavour to present to the listener. In this context it should be remembered that in an amplifier which has a flat power response from 30Hz to 180kHz, 90% of this power spectrum will be supersonic.

This unwanted output can arise in two ways. It can be because of wide spectrum "white noise" from a preamplifier with a significant amount of hiss – this can happen if a valve preamplifier is mismatched into the few thousand ohms input impedance of a transistor power amplifier, and will also cause the system performance to be unnaturally lacking in bass. Trouble of this type can also arise if transient instability or high frequency "ringing" occurs, for example when a reactive load is used with a class B amplifier having poor cross-over point stability.

### Reference

1. Bailey, A.R., "High-performance Transistor Amplifier", *Wireless World*, November 1966; "30-Watt High Fidelity Amplifier", May 1968 and "Output Transistor Protection in A.F. Amplifiers", June 1968.

Figures

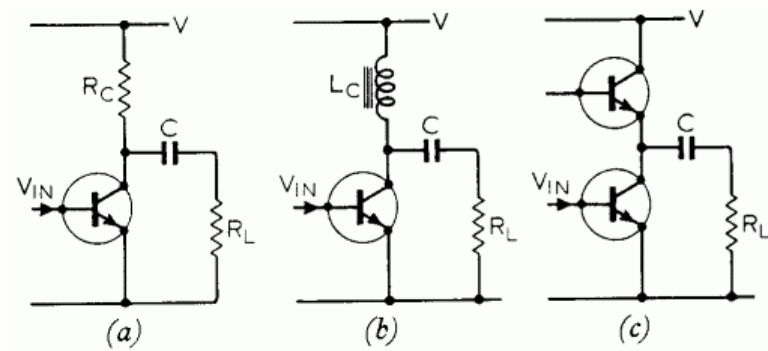

Fig. 1. Basic class A circuits using (a) load resistor  $R_C$  giving power conversion efficiency of about 12%, (b) i.f. choke giving better efficiency but being bulky and expensive, and (c) a second transistor as collector load.

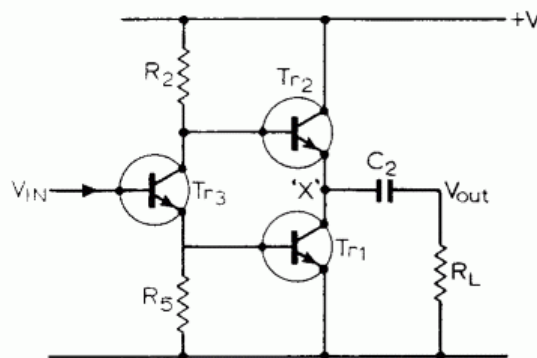

Fig. 2. Arrangement for push-pull drive of class A stage.

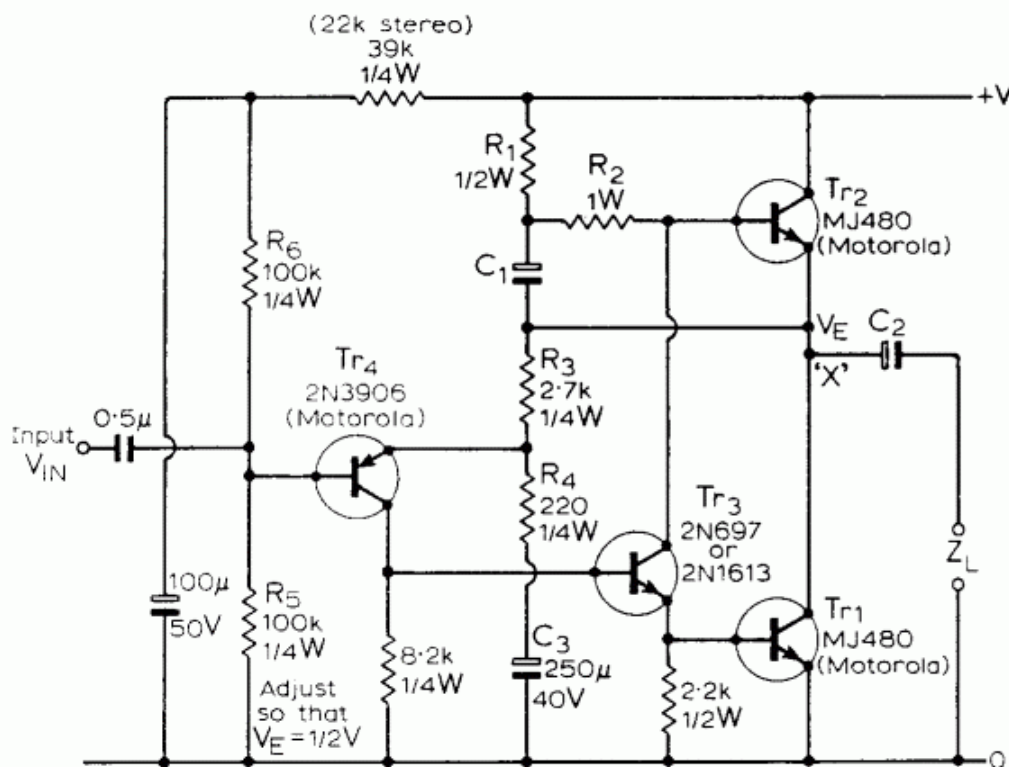

Fig. 3. Practical power amplifier circuit.

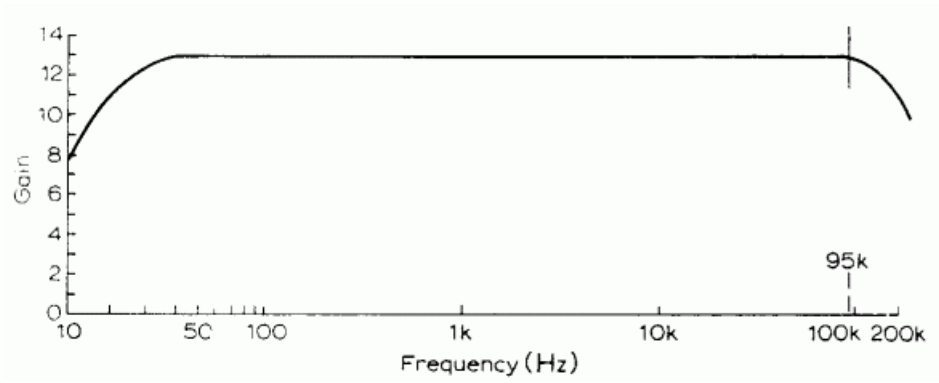

Fig. 4. Gain/frequency response curve of amplifier.

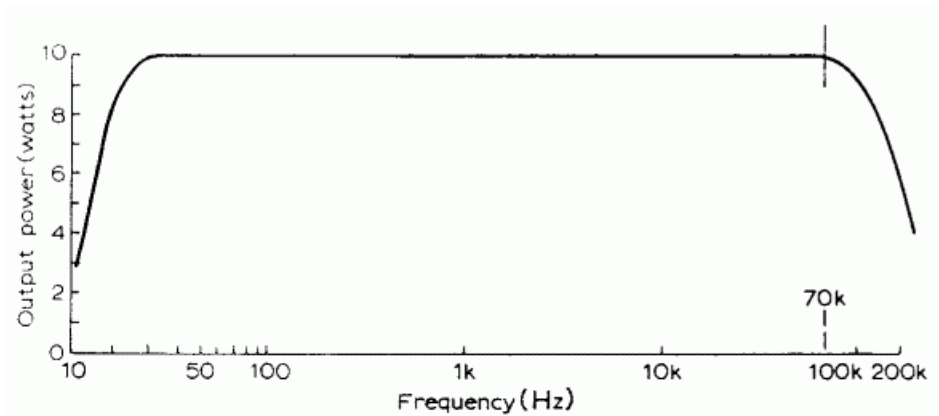

Fig. 5. Output power/frequency response curve of amplifier.

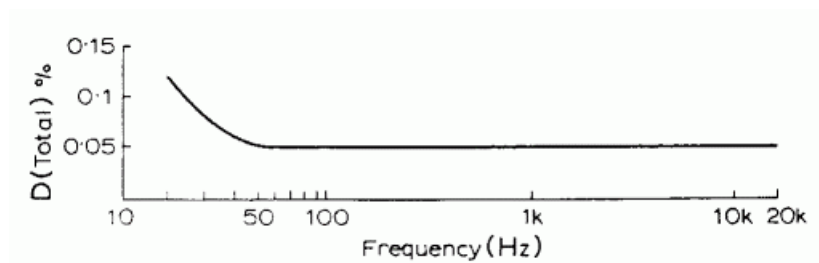

Fig. 6. Distortion/frequency curve at 9W.

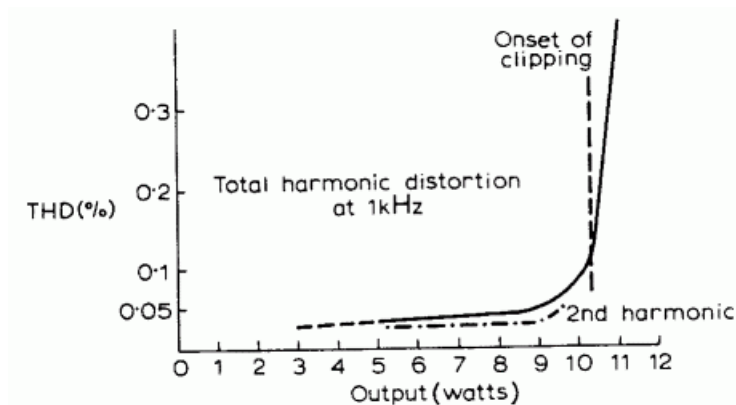

Fig. 7. Distortion/output power curve.



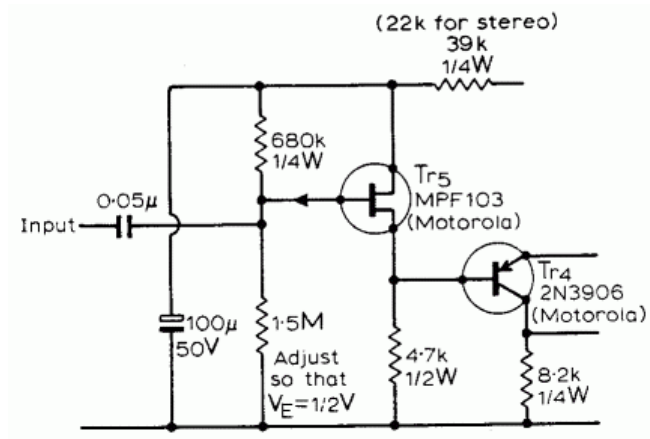

Fig. 8. Modified input circuit for high input impedance.

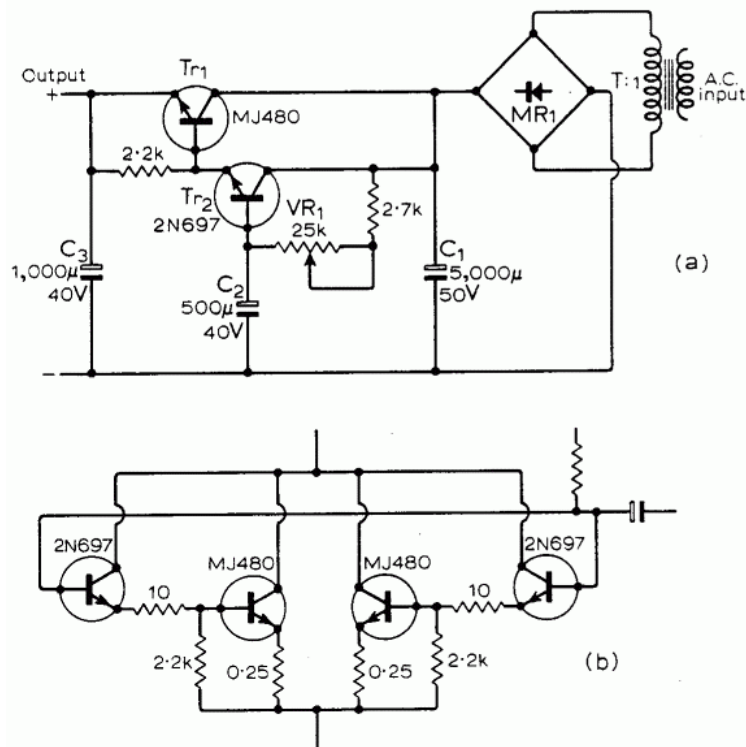

Fig. 9. (a) Power supply unit, and (b) parallel connected transistors for high currents.

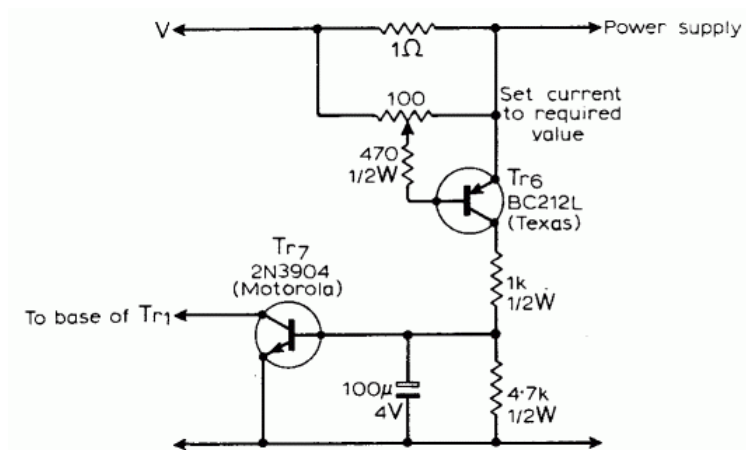

Fig. 10. Amplifier current regulation circuit.

# Simple Class A Amplifier

**A 10-W design giving subjectively better results than class B transistor amplifiers**

by J. L. Linsley Hood, M.I.E.E.

## Oscilloscope Traces

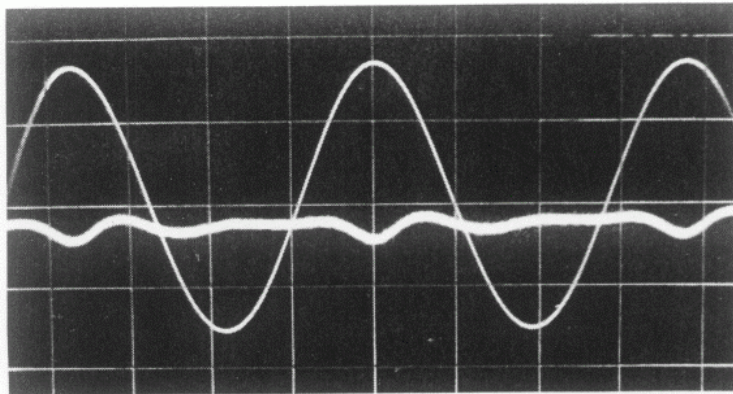

*Sine wave performance at 1kHz. 9 watts; 15 ohm resistive load. Fundamental on scale of 10V/cm. Distortion components on scale of 50mV/cm with r.m.s. value of 0.05%.*

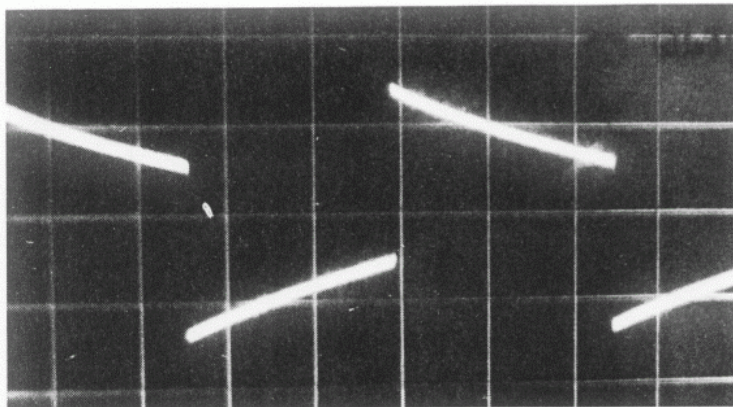

*Square wave response at 50Hz.*

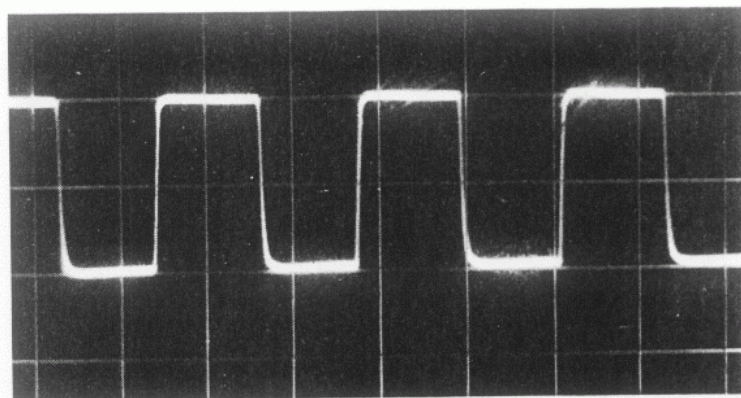

*Square wave response. Scale 10V/cm. Frequency 50kHz. 15 ohm resistive load.*

Photographs

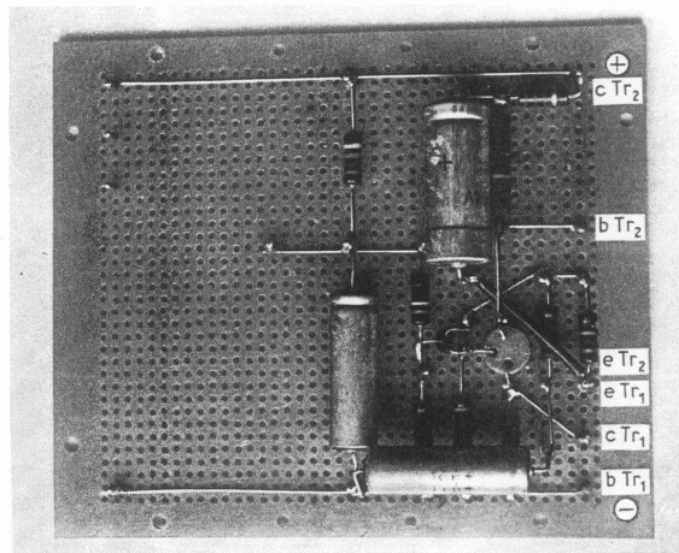

*Layout of single channel of 10 + 10 watt amplifier on standard 4in x 4 3/4in 'Lektrokit' s.r.b.p. pin board.*

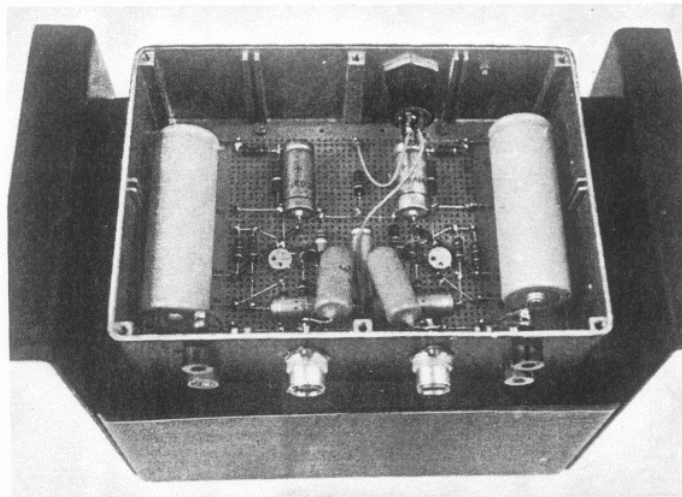

*Underside of completed amplifier, with base cover removed, showing external box-form heat sink.*

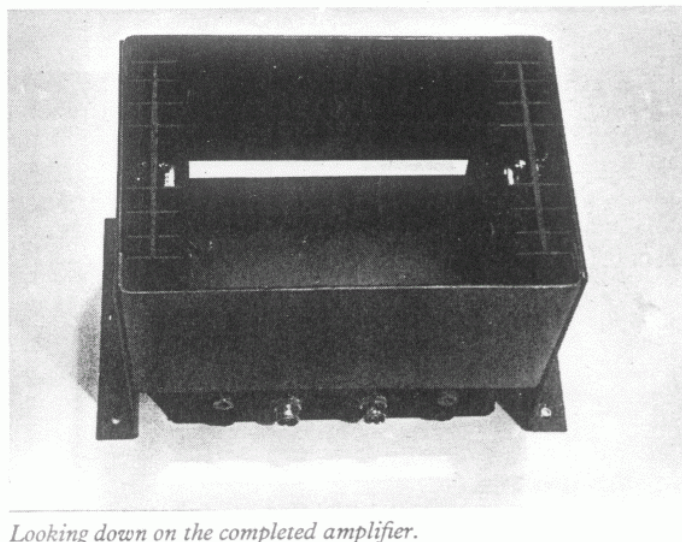

*Looking down on the completed amplifier.*

# Class-A Power

**After two and a half decades, John Linsley-Hood's Class-A power amp is still rated among the best. Here, John explains how to bring the design up to date, adding enhancements such as dc-coupled output.**

The current debate, among the more reactionary of the hi-fi devotees, about the relative merits of thermionic valve operated audio amplifiers makes intriguing reading, if only because, in a sense, this is 'where I came in'. I will explain.

I have had an interest in the reproduction of music, principally from gramophone records, for a very long time. I made my first, two-valve, battery-operated, audio amplifier as a twelve year old school boy, some time before the outbreak of the 1939-1945 war.

This gave way – in the interests of economy, – to a series of mains powered amplifiers, which were usually combined with a radio receiver. Electricity from the mains was free, to me at least, whereas high-tension batteries had to be bought from my pocket money.

My early work culminated, in 1951, with the assembly of a luxurious kit for the highly esteemed high-fidelity Williamson 15W amplifier design. Although, by this time, I had my first proper job – in the electronics labs of the Sellafield nuclear research establishment in Cumberland – and cash was a bit more plentiful, I still wouldn't have built that particular, rather expensive version of the hardware if I hadn't heard through the lab grapevine that one of the research chemists had bought himself a Williamson kit, but, on receiving the parcel, lacked the courage to assemble its contents. Rumour had it that he was open to offers, and I was happy when he accepted mine.

This was an excellent amplifier, and was better, in my judgement, by a greater or lesser extent, than any of its predecessors of my own design, or, indeed, any of the other valve amplifiers, belonging to my friends, with which I had had a chance to compare it. It gave me great pleasure until early 1968, when I replaced it with a solid-state equivalent.

What I replaced it by, and the circumstances of this replacement, were described in an article in *Wireless World* in April 1969, entitled 'A simple class A amplifier'. This was a long time ago. In the light of the current debate, it seems possible that both my listening trials at the time, and an up-dated version of my original class A design, may be of interest to you. By up-dated, I mean using more modern components and delivering a bit more power output.

## The Williamson Amplifier

In the inter-war years, with the improvement in audio quality of both gramophone records and radio broadcasts, considerable attention was paid to improving the quality of ac mains-powered audio amplifiers. A number of interesting designs were offered. These were mainly based on the use of push-pull output stage layouts. Relative to straight single ended circuits, push-pull stages would give greater output power for a given distortion level.

At that time, there were audiophiles who decried the use of push-pull output stage layouts. They claimed that the best audio quality was only obtainable from the much less efficient single ended arrangements, i.e. those in which the output valve had a simple resistor, choke or output transformer load. Interestingly, this is a claim which was examined and dismissed by Williamson at the time, but which has recently been resurrected.

## Using negative feedback

Almost all valve operated audio power amplifiers require an output transformer to match the relatively high output impedance of the valve output stage to the low impedance load presented by the loudspeaker.

In general, the transformer is the most difficult and expensive part of the system to design and construct. This is because of the following conflicting demands:

- For a low leakage reactance – combining both leakage inductance and inter-winding capacitance – from the primary to the secondary windings, to avoid loss or impairment of high frequency signal components.
- For a low level of leakage inductance from one half of the primary to the other, to reduce the discontinuities due to push-pull operation, and the odd-order harmonic distortion resulting from these.
- For a high primary inductance, to give a good low-frequency response.
- For a low winding resistance, to avoid power losses.
- For a good quality grade of core laminations to ensure a low level of core-induced distortion, due to magnetic hysteresis and similar effects.

Intrinsic signal distortion of a valve amplifier stage could range from 0.5 to 10%, depending on its circuit form and operating characteristics. It had been appreciated for some time that such intrinsic distortion could be reduced significantly by applying local negative feedback. Various amplifier designs incorporating local negative feedback had been proposed. However, this still left the output transformer – however well made – as a major source of transfer and frequency response non-linearities.

At this point, D. T. N. Williamson, who was working at the time as a development engineer for the valve section of the GEC Research Laboratories, described a high-quality audio amplifier design, using the recently developed GEC 'kinkless tetrode' output valve, namely the KT66. In this design, a single overall negative feedback loop embraced both the whole of the amplifier and the loudspeaker output transformer.

With the exception of the output valves, which were triode connected KT66s, Williamson's design employed triode amplifier valves exclusively, because these had a lower intrinsic distortion figure. He also made use of extensive local negative feedback, provided by un-bypassed cathode-bias resistors. This had the additional benefit of eliminating the electrolytic bypass capacitors – a philosophy which is in accord with much of contemporary thinking.

Williamson also used non-polar rather than electrolytic high-tension reservoir and smoothing capacitors, in the interests of more consistent ac behaviour. Electrolytic capacitors were much worse at that time.

If overall negative feedback was to be applied without causing either high or low-frequency instability, careful design was essential – both in the amplifier stages and in the output transformer. These problems had frustrated earlier attempts to do this – but Williamson demonstrated that it could be done.

The performance given by his design, if his detailed specifications were carried out to the letter, was superb. The performance criteria of better than 0.1% thd, at 15W output, from 20Hz to 20kHz, and a gain bandwidth from 10Hz to 100kHz +/- 1dB, are at least as good as those offered by many of today's better commercial designs.

The series of articles written by Williamson, in *Wireless World* over the period 1947 – 1949 described the power amplifier and its ancillary units. This series had enormous impact on audio design thinking, and if I may quote the *WW* editor of the time, in his introduction to a reprint of all these articles.

"Introduced in 1947 as merely one of a series of amplifier designs, the 'Williamson' has for several years been widely accepted as the standard of design and performance wherever amplifiers and sound reproduction are discussed. Descriptions of it have been published in all the principal countries of the world, and so there are reasonable grounds for assuming that its widespread reputation is based solely on its qualities".

All in all, the Williamson was a hard act to follow.

## Alternative hardware

The world had not stood still since 1951. My equipment had remained monophonic, while the rest of the audio world was changing over to stereo.

My main interest was in music, not in circuitry, so I thought it would be prudent to ask my ears what they thought of the alternatives, before I started to replace my hardware.

To this end, I built or borrowed six well thought-of audio amplifiers, my own Williamson, a Quad 2, two dissimilar but recently published class AB transistor amplifiers, a commercial 30W solid-state unit, and a simple Class-A unit of my own design.

I included the Class-A design out of curiosity. If it turned out to be any good, it would be cheap and easy to build. It was not expected to offer any special merit in performance.

In the event, as I reported at the time, (WW April 1969, p.152), the six amplifiers divided quite clearly into two separate tonal groups. The three class AB transistor amplifiers formed one group, while the two valve amplifiers and the simple class A amplifier formed the other.

To be fair, the differences between any of these were not very great – but they were audible. Once they were noticed, they tended to become more apparent on protracted periods of listening. Certainly, for me – and I was doing these tests for my own benefit – in these comparative trials, the two best were the Williamson and the class A. They were virtually indistinguishable. Of these two, the Williamson was vastly more massive and costly to construct.

The only remaining question was, if I replaced the 15W Williamson with the 10W Class-A design, would the output be adequate? Connecting an oscilloscope across the loudspeaker terminals showed that I seldom needed more than 2-3W from the power amplifier – even under noisy conditions.

I suppose that the final proof of my satisfaction with the class A transistor amplifier was that, a year or so later, I gave my old Williamson to a friend.

## Valves versus transistors

Not all of the considerations of valves versus transistors relate solely to performance. It is worth bearing in mind that products involving obsolete technology will be disproportionately expensive, difficult to obtain and possibly of inferior quality.

Valves can also vary in operating characteristics from sample to sample – especially where two valves of the same type are obtained from different sources. Characteristics that can vary are mutual conductance, gain, operating grid bias, anode current impedance, and even usable anode voltage.

By comparison, the performance characteristics of, say, a range of 2N3055 epitaxial base output transistors are almost identical, whether made in the Philippines or in Toulouse.

Again, all valves deteriorate in use, exhibiting a gradual loss of cathode emission over a typical 3000 hour service life. If a valve is persistently over-driven, the heating of the anode may cause the metal to out-gas. This impairs the vacuum essential to proper operation, and shortens the valve's life.

A further consideration is that valves are high voltage devices, which can be dangerous. And the need for high working voltages can lead to more rapid failure of other components in the circuit – especially capacitors.

## The class A design

My original design is shown in Fig. 1. This is still a valid design, except that the MJ480/481 output transistors are now obsolete. However, they can be replaced by the more robust 2N3055. In this case, the epitaxial-base version of this device should be chosen rather than the homotaxial, since the  $f_T$  of the output transistors should be 4MHz or higher.

As I commented, at the time, the design gave a somewhat lower distortion if the  $h_{FE}$  of Tr1 was greater than that of Tr2. This caused the output circuit to act as an amplifier with an active collector load rather than an output emitter follower with an active emitter load.

A simple modification which takes advantage of this effect is the use of a Darlington transistor such as an MJ3001 for Tr1. At 1kHz, this reduces the distortion level at just below the onset of clipping from about 0.1% down to nearer 0.01%. As before, the residual distortion is almost exclusively second harmonic. Also, as before, it fades away into the general noise background of the measurement system as the output power is reduced.

While this transistor substitution seems to be a good thing, it was not a modification whose effect I was able to check, in listening trials, against the Williamson. As a result, for the sake of historical fidelity, I would still recommend the use of epitaxial-base 3055s as Tr1 and Tr2.

I have checked all the other changes which I have proposed with the exception of the power increase.

## Improving performance

With regard to the original 10W design, as published, I feel the following improvements will be beneficial:

- Provide a more elegant means of controlling output transistor operating current by including a variable resistor in the base of Tr2.
- Arrange the circuit so that it would operate between symmetrical power supply lines, allowing the amplifier to be directly coupled to the loudspeaker.
- Increase output power from 10 to 15 watts per channel
- Up-grade the smoothed but not regulated power supply arrangement.

In my postscript to this design, which WW published in December 1970, I suggested both alternative transistor types and an improved method of adjustment and control of the output transistor current flow, Fig. 2.

Although, in theory, this layout should give a superior performance, when I changed my prototype amplifier to this arrangement, I found little change in measured thd and I couldn't hear any difference in sound quality.

Although directly coupling the amplifier to the loudspeaker will not have much effect on thd, it is still beneficial since it eliminates the output coupling capacitor. The most obvious way of doing this is to rearrange the input layout, around Tr4, so that it becomes the input half of a 'long-tailed' pair.

I am reluctant to do this because this would alter the overall gain/phase characteristics of the amplifier. It would also require additional high-frequency stabilisation circuitry, with all its incipient problems of transient intermodulation or slew-rate limiting.

Fortunately, the need to remove the dc offset at the output can be achieved without altering the good phase margins of the design, by simply injecting an appropriate amount of current into the base circuit of Tr4.

## Output power and dissipation

In essence, all that is required to increase the power output from the amplifier is to increase the rail voltages and the standing current through the output devices. Restrictions are that power consumption must remain within the confines of what the mains transformer and rectifier can deliver. Also, the heat-sinks must be able to dissipate the extra heat and the output transistors must be adequately rated.

For a 15W (sinusoidal) output into an  $8\Omega$  load, an  $11V_{RMS}$  drive voltage is required. This, in turn means a  $31V_{P-P}$  voltage developed across the load, and an output current into the load of 2A. Since the circuit is a single-ended configuration, in which the collector current will not increase on demand, this means that the output transistor operating current must be at least 2A to allow this.

With the circuit shown, using the improved current control layout – which is rather less efficient than the boot-strapped load for Tr3 which I originally proposed – the rail voltage needed is +/- 22V.

This will lead to a dissipation, in each output transistor, of 44W. Prudence suggests that a heatsink having a rating of no more than  $0.6^{\circ}C/W$ , should be used for each output pair.

Most 2N3055s have a  $V_{ce}$  of 60V, a maximum collector current of 15A, and a maximum dissipation, on a suitable heatsink, of 115W. However, RCA's 3055, and its complementary MJ2955, are rated at 150W.

Working conditions for the output transistors are entirely within the devices safe operating area, so no specific overload protection circuitry is needed. Even so, the inclusion of a 3A fuse in the loudspeaker output line would seem prudent.

## DC offset cancellation

Figure 3 shows the full circuit for one channel of the 15W Class-A audio amplifier. I have inserted a 15V three-terminal regulator ic into the positive rail to prevent any unwanted signal or hum intrusion into the emitter of Tr4.

It is easy to set the dc offset to within +/-50mV. The offset does not change greatly with time, although this assumes that Tr5 is not allowed to warm up too much. This is because the base-emitter potential of this transistor controls the operating current, which in turn, affects the output dc offset.

## Small-signal bandwidth

In the original circuit the small-signal bandwidth was 10Hz–250kHz, +/-3dB, which was needlessly wide. Because of this, I have added an input high-frequency roll-off network, R3/C2, to the input circuit to limit the top end response to some 50kHz. This assumes an input source impedance of  $10k\Omega$  or less.

As it stands, the low-frequency -3dB point is about 7Hz. It can be lowered even further, if necessary, by making C1 larger – say to  $1\mu F$ .

## Supplying power

As was shown in the 1970 postscript, it is possible to operate this amplifier from a simple rectifier/reservoir capacitor layout. Fig. 4 is an example. The only penalty is a small 100Hz background hum, probably about 3mV in amplitude. However, I feel that, if you are seeking the best, a proper regulated power supply is preferable, Fig. 5.

The circuit shown for the current booster pass transistors, Tr1/Tr2, is one suggested by National Semiconductor. It takes advantage of the internal current limiting circuitry of the 7815/7915 devices to limit the short-circuit current of these ICs to 1.2A. By choosing the correct ratios of R5:R7 and R8:R10, the short-circuit current drawn from Tr1 and Tr2 will also be limited.

For a satisfactory ripple free dc supply of +/-22V, the on-load voltage supplied to the regulator circuit should be +/-27V.



## Performance

I prefer measurements made with appropriate instruments to judgements based on listening tests.

Measured distortion is less than 0.1% near the onset of clipping. It fades away into the background noise level of the measuring system as output power level is reduced.

For me, the fact that the distortion given by this circuit is almost pure second harmonic is more persuasive of its performance than any 'golden eared' judgement of tonal purity.

If you then add the observation that the circuit remains stable on a square-wave drive into typical reactive loads, I am not surprised that its performance was capable of equalling the Williamson on listening tests. No significant overshoot is observed on the square-wave, and stability is achieved without the need for internal high-frequency compensation arrangements.

So, as a final thought, if any of you want to find out how a top quality valve amplifier like the Williamson sounds, you can find out at a tenth of the cost of building one by making up this Class-A design. It has the additional advantage of incorporating readily available and modern components.

## Figures

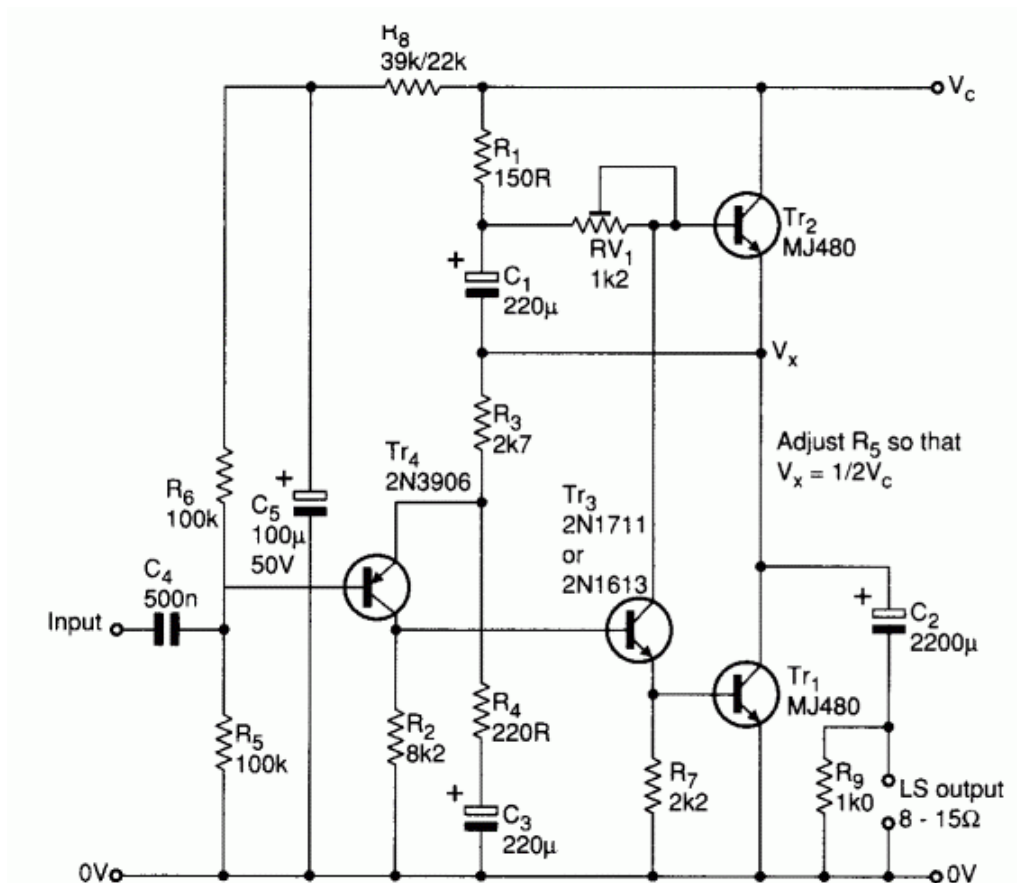

**Fig. 1. Original 10W Class-A design is still valid, but the power devices are now obsolete.**

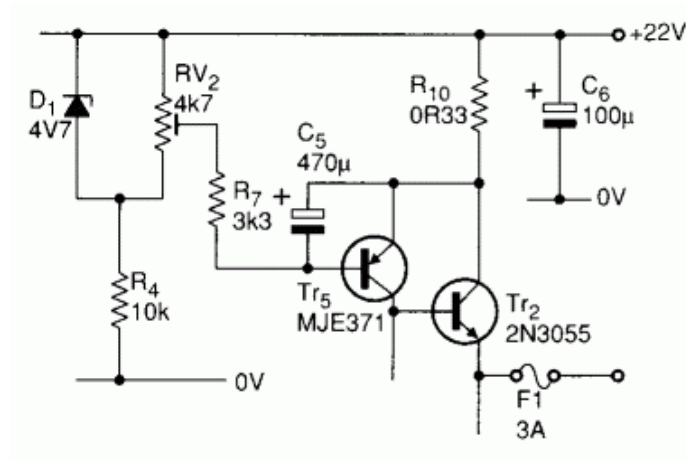

**Fig. 2. Improved method of adjusting quiescent current, suggested as a postscript to the original design.**

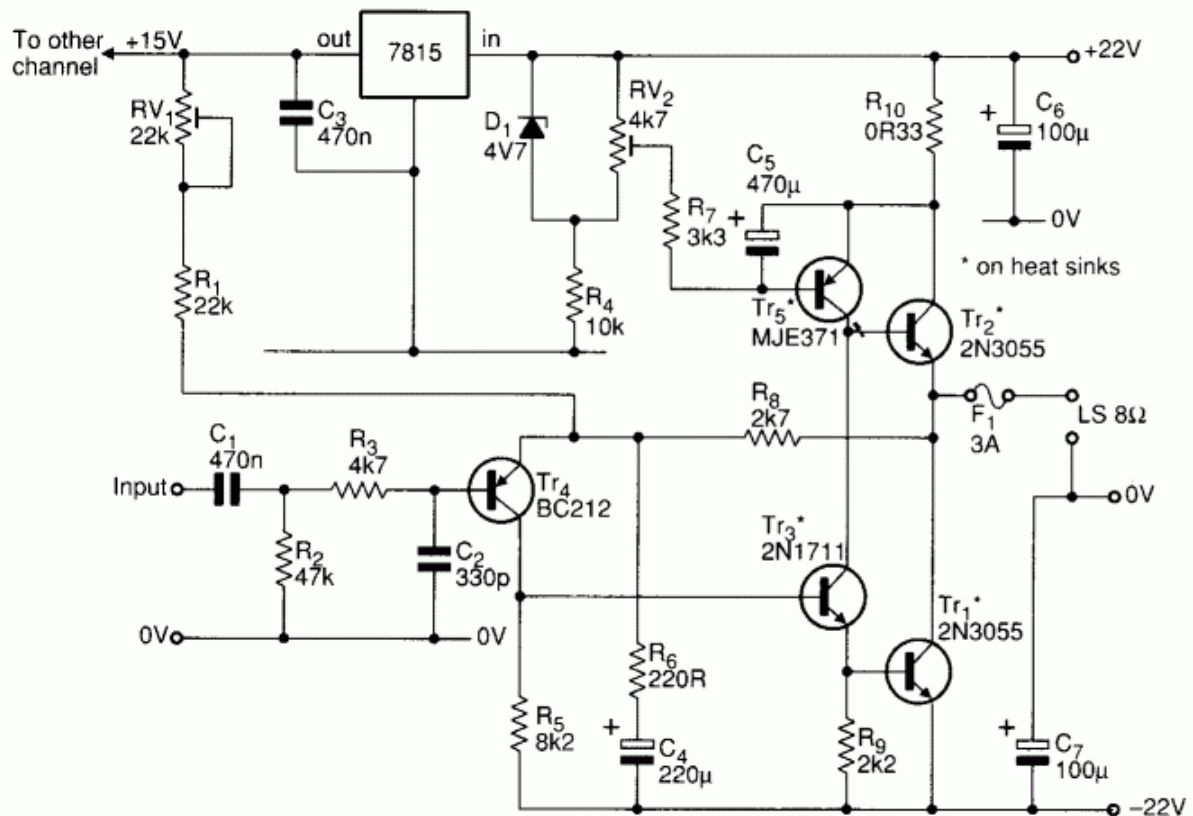

**Fig. 3. One channel of the enhanced 15W Class-A design incorporating – amongst other things – direct loudspeaker coupling.**

Note: There is an error in this diagram. The negative end of C4 should be connected to the 0V (earth) point and not the -22V supply rail as shown. Failure to do this will result in excessive hum due to supply rail ripple being injected into the negative feedback path (Tr4 emitter).

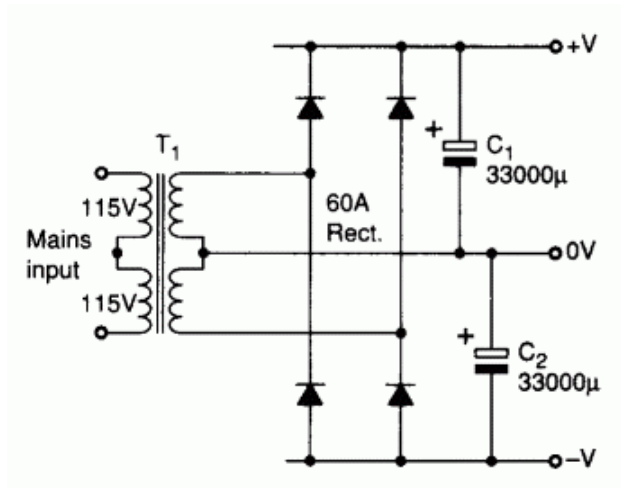

Fig. 4. Simple but adequate dual-rail supply using a single bridge.

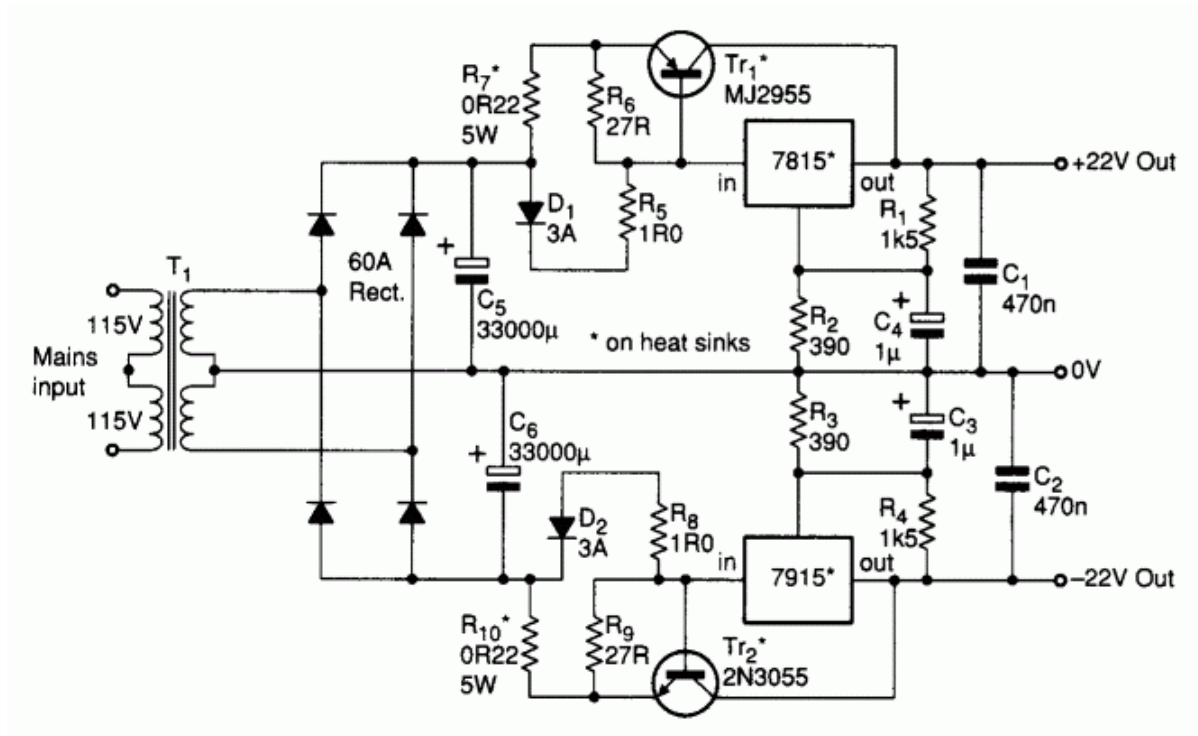

Fig. 5. Regulated power supply for the Class-A amplifier uses boosters around the three-terminal regulators. These take advantage of the regulators' current-limiting feature.